



# **Industrial Data Communication Applications Interfacing with GE Fanuc Equipment**



GE Fanuc

Data-Linc Group Interfacing Guides are also available for Omron, Rockwell Automation, Schneider Electric and Siemens. To obtain any of these guides, please contact Data-Linc Group via email at [marketing@data-linc.com](mailto:marketing@data-linc.com), telephone 425.882.2206 or fax 425.867.0865.

## **Industrial Data Communication Applications Interfacing with GE Fanuc Equipment**

- GE Fanuc\_Cooperative Accompany™ Program participant
- Seamless interface with GE Fanuc PLCs
- Stand-alone and chassis mount modems available—including license-free, wireless spread spectrum frequency hopping modems
- Factory preconfigured for easy installation
- Reliable, worry-free data communication—even in harsh environments

### **Introduction**

Data-Linc Group designs and manufactures industrial data communication devices. Data-Linc Group is dedicated to providing the broadest line of superior quality, high performance modems, data communications peripherals and systems for any industrial application—including harsh environments that require extended operating temperatures.

### **Industries**

Data-Linc Group products have been successful in providing continuous data communication in water/wastewater, utility/power, oil/petrochemical, mining/quarrying, transportation, stone/aggregate, cement/concrete, pulp/paper, food, material handling and bio-pharmaceutical industries and other markets.

### **Application Engineering**

Data-Linc Group provides unsurpassed application engineering and customer service. Data-Linc Group application engineers provide comprehensive requirements analysis to recommend the best data communication solution possible. Because of this in-depth analysis, Data-Linc Group can custom preconfigure each modem and cable to ensure fast and convenient installation.

Data-Linc Group technical services staff provide unlimited support to ensure complete customer satisfaction. Data-Linc Group can often simulate PLC communication anomalies in their fully equipped support lab to provide fast and easy answers to data communication problems.

### **Compatibility**

Data-Linc stand-alone and chassis mount modems are ideal for CCM, RTU, SNP and SNP-X GE Fanuc Series 90 Communications Protocols (for 90-30 and 90-70 PLCs) and bridge systems. Data-Linc provides factory configured RS-232 and 422/485 four wire cables for plug-and-play direct connection to GE Fanuc PLCs, PCs and communication interfaces.



GE Fanuc

# Water District: SNP Protocol RF Communication

**Data-Linc Group license-free, wireless SRM6000 serial spread spectrum modems and GE Fanuc 90-30 PLC**

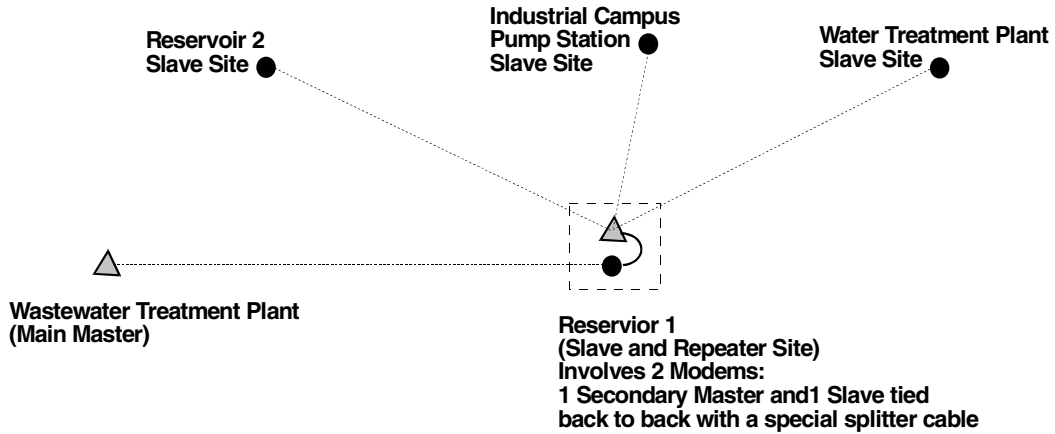

Qty. 4 SRM6000-L/SNPR  
Qty. 2 SRM6000-L/SNPM

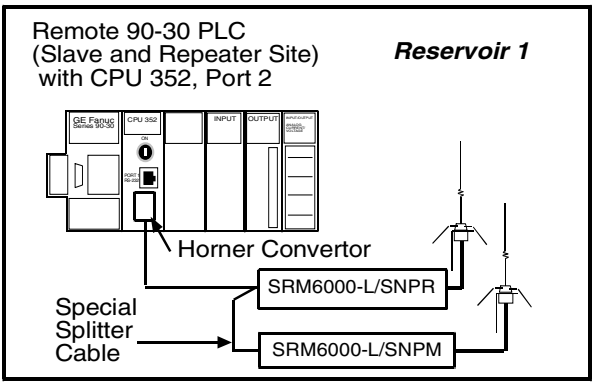
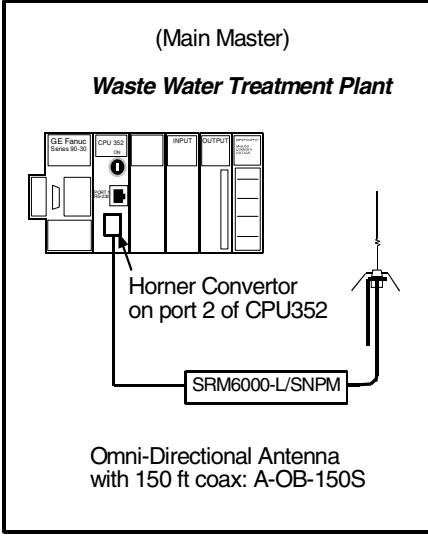
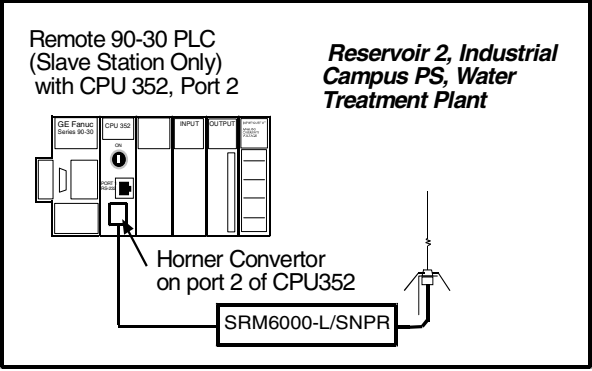
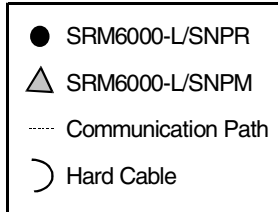

Port 2 on a GE Fanuc CPU352 can function as a Master or Slave Port for SNP/SNPX Protocol. It can function as a Slave Port for RTU Protocol as well as serial I/O. If CCM protocol is desired the 90-30 PLC must have a CMM311 Comm Coproc Module.

# Water District: CCM Protocol

Data-Linc Group license-free, wireless SRM6000 serial modems

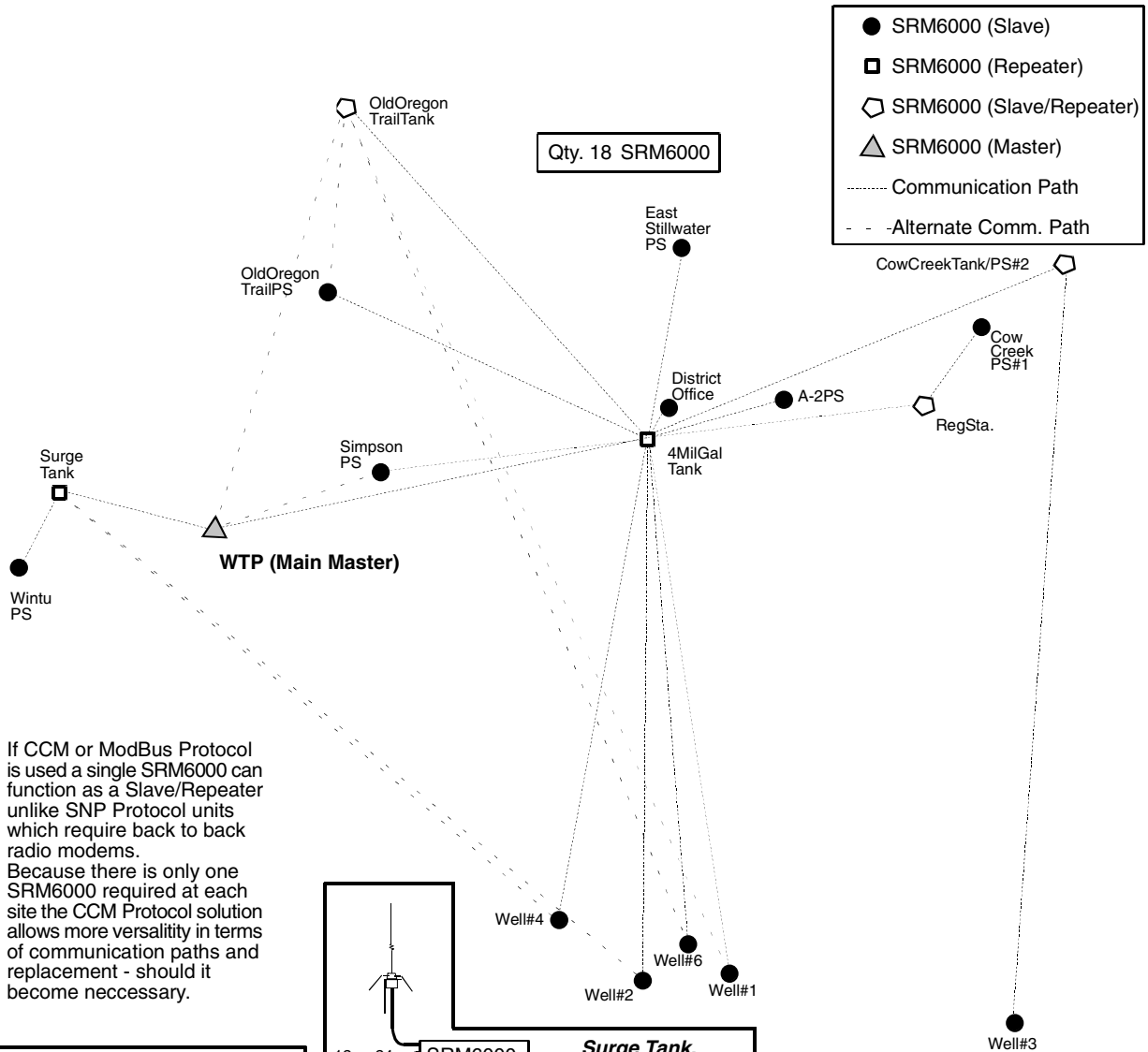

If CCM or ModBus Protocol is used a single SRM6000 can function as a Slave/Repeater unlike SNP Protocol units which require back to back radio modems. Because there is only one SRM6000 required at each site the CCM Protocol solution allows more versatility in terms of communication paths and replacement - should it become necessary.

**Wintu PS, Simpson PS, A-2 PS, Old Or Trail PS, E. Stillwater PS, Cow Creek PS #1, Wells 1-6.**

Remote 90-30 PLC (Slave Station Only) with CMM311 Comm. Module

(Slave)

12 or 24 VDC for 24 VDC use pt# SRM6000/24V

**Surge Tank, 4 Mil Gal. Tank**

(Point to Multi-Point Repeater)

Remote 90-30 PLC (Slave/Repeater Station) with CMM311 Comm. Module

(Slave/Repeater)

**Cow Creek Tank/ PS #2, Old OR Tr. Tank, Reg Station**

Master 90-70 PLC (Master Only) CMM711 Comm. Module

(Master)

**WTP**

# Petroleum: Crude Oil Facility Application

## Data-Linc Group license-free SRM6200E Ethernet modems and GE Fanuc 90-30 PLCs

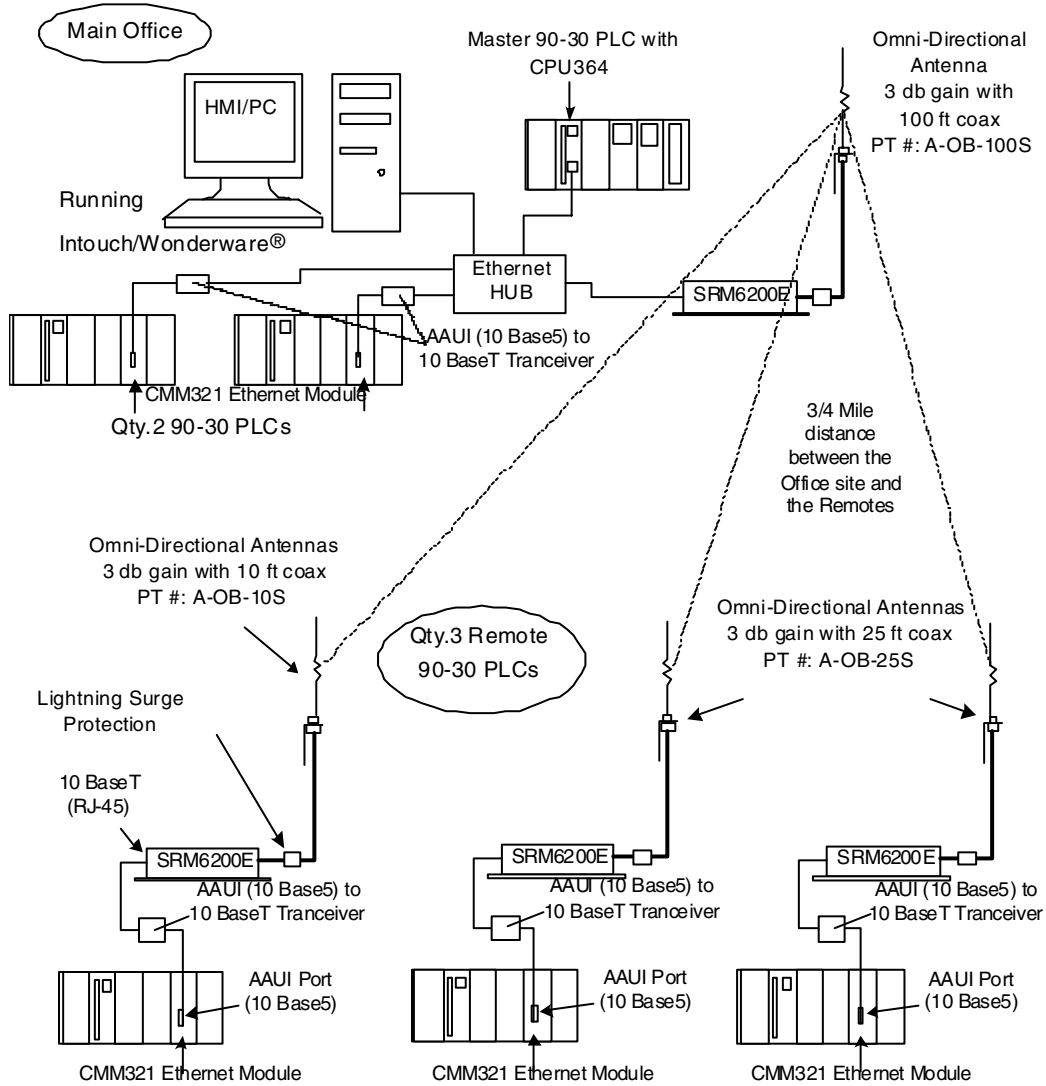

This system provides data acquisition and control of remote operations within a crude oil storage and distribution facility. At the main office, the HMI and 90-30 PLCs all have access to the three remote PLCs. Data throughput of the SRM6200E is roughly 100 KBPS. Data-Linc recommends lightning surge protection in-line with the antenna coax cables.

# Overhead Crane Storage/ Retrieval Application

**Data-Linc Group license-free SRM6200E Ethernet modems  
and GE Fanuc 90-30 PLCs**

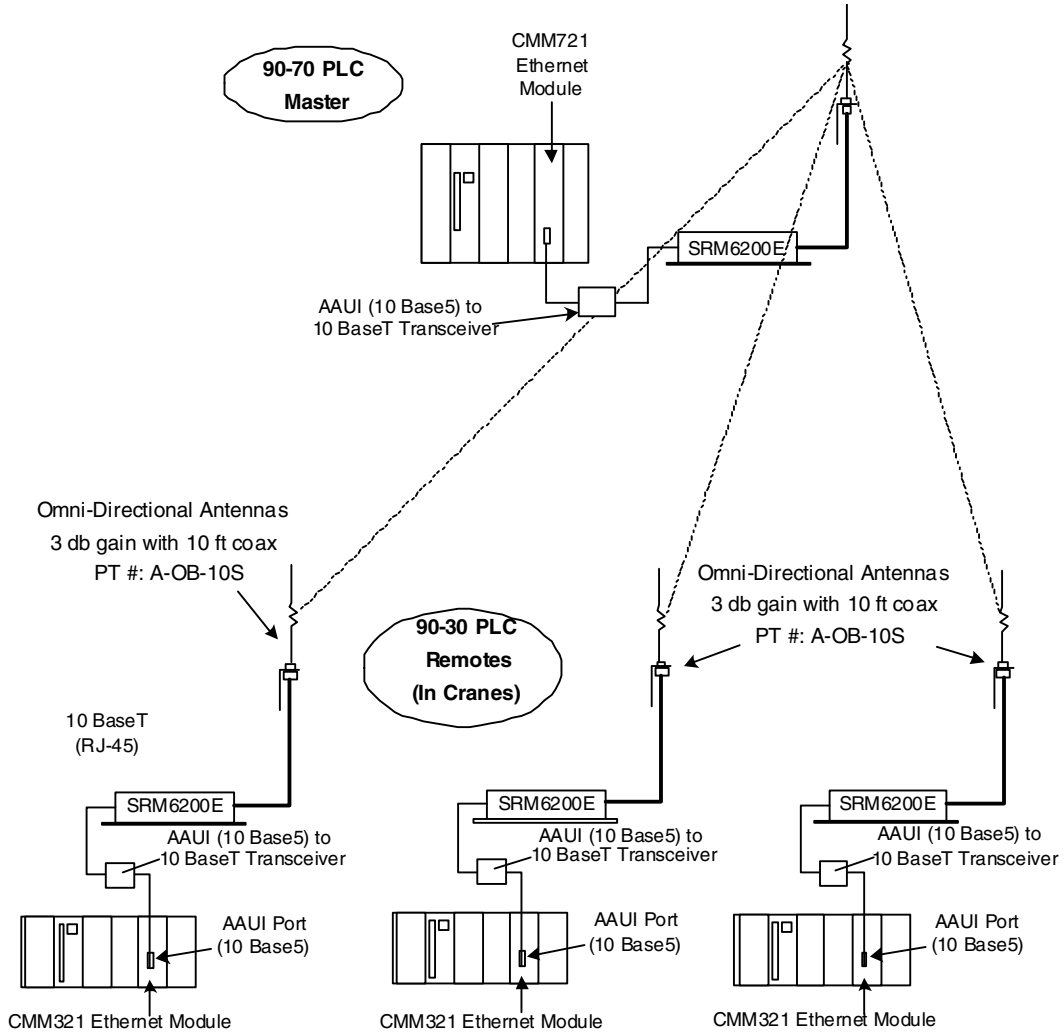

This system provides control of overhead cranes for storage and retrieval of alkaline batteries in a warehouse. There are 3 cranes each with a GE Fanuc 90-30 PLC and SRM6200E running up and down long rows of steel shelving that extends the length of the building and from floor to ceiling. The shelving holds steel and aluminum containers filled with AAA to D size alkaline batteries. The antennas of the crane based SRM6200E are normally not within line-of-sight of the base station SRM6200E at the 90-70 PLC. This situation poses a serious challenge to most 902-928 MHz RF transceivers due to the presence of considerable metallic obstacles between the RF Transceivers. The SRM6200E performs flawlessly despite the obstacles and RFI from the crane motors and other devices in the warehouse.

# Leased Line SCADA Application

## Leased Line Multi-Point Communications at 19.2K Baud utilizing Data-Linc Group DLM4000/LL and GE Fanuc 90-30 PLCs

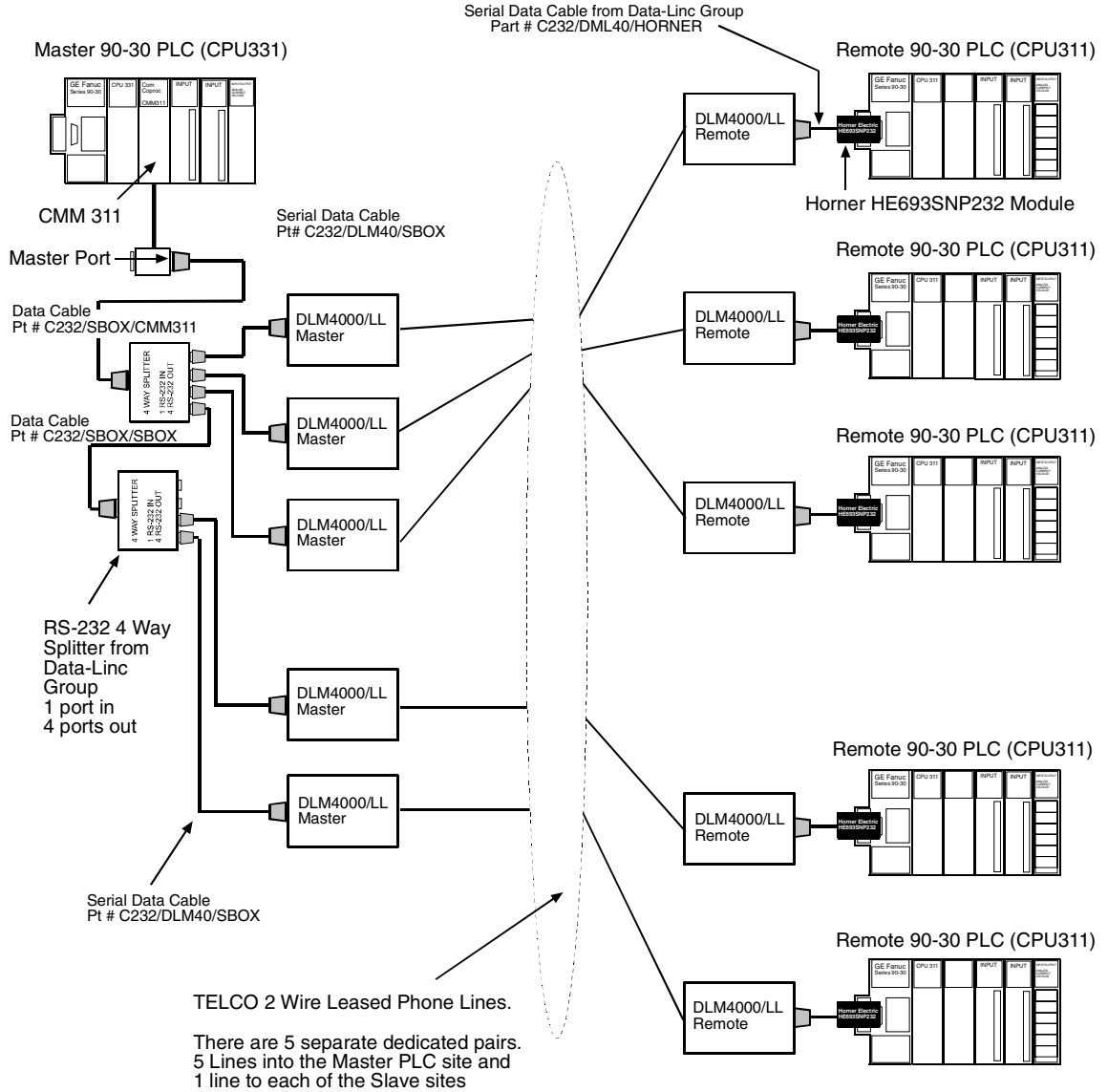

This is a point to multi-point SCADA application using leased telephone lines. The leased line modems from Data-Linc Group are part number DLM4000/LL. In this application they are running at 19.2 K Baud and providing SNP Protocol data link communications for remote data acquisition. This data link also allows one to view the programs in the remote 90-30 PLCs as well as reprogram them. The 5 Master DLM4000/LL Modems are PCB only and reside in a 19" rack. Each of the DLM4000/LL Modems are powered on at all times and have connection to their corresponding remote modem. The communications are 1/2 duplex where only one of the remote PLCs talks back at a time.



**DATA-LINC GROUP**

# **Power Line Modem Application**

**Data-Linc Group LCM100 Power Line Modems**

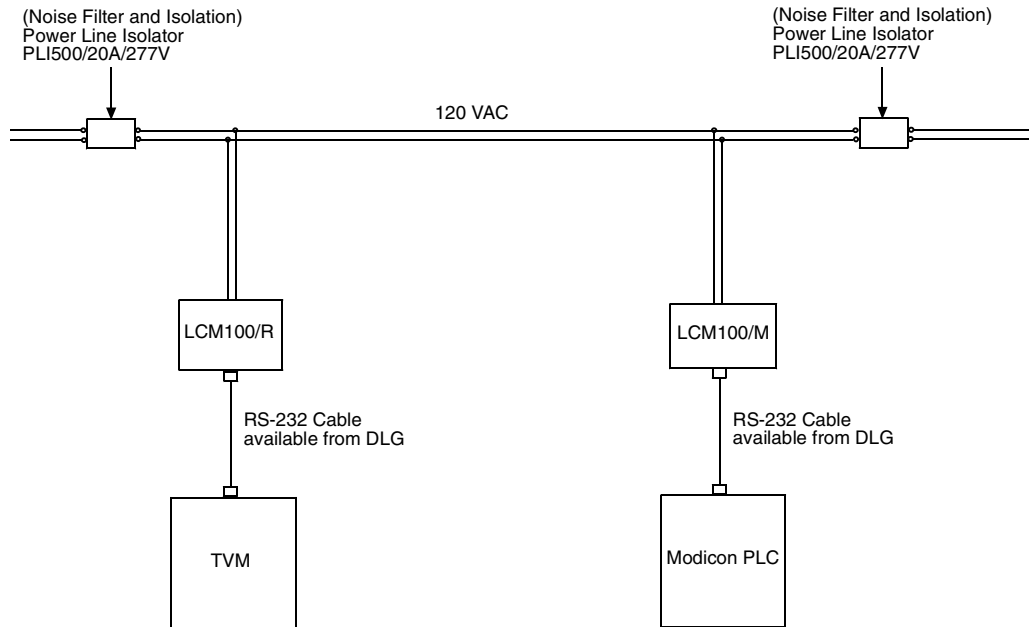

## **Contact Information**

### **Corporate**

#### **Data-Linc Group**

2635 151st Place NE  
Redmond, WA 98052 USA

<b>Tel</b>	425.882.2206
<b>Fax</b>	425.867.0865
<b>Email</b>	<a href="mailto:info@data-linc.com">info@data-linc.com</a>
<b>Web</b>	<a href="http://www.data-linc.com">www.data-linc.com</a>



GE Fanuc